

Myers®

Pentair Pump Group

3V/3VX*

Submersible Non-Clog Pumps Installation and Service Manual

*Used in Hazardous Locations Class 1, Division 1, Group C & D

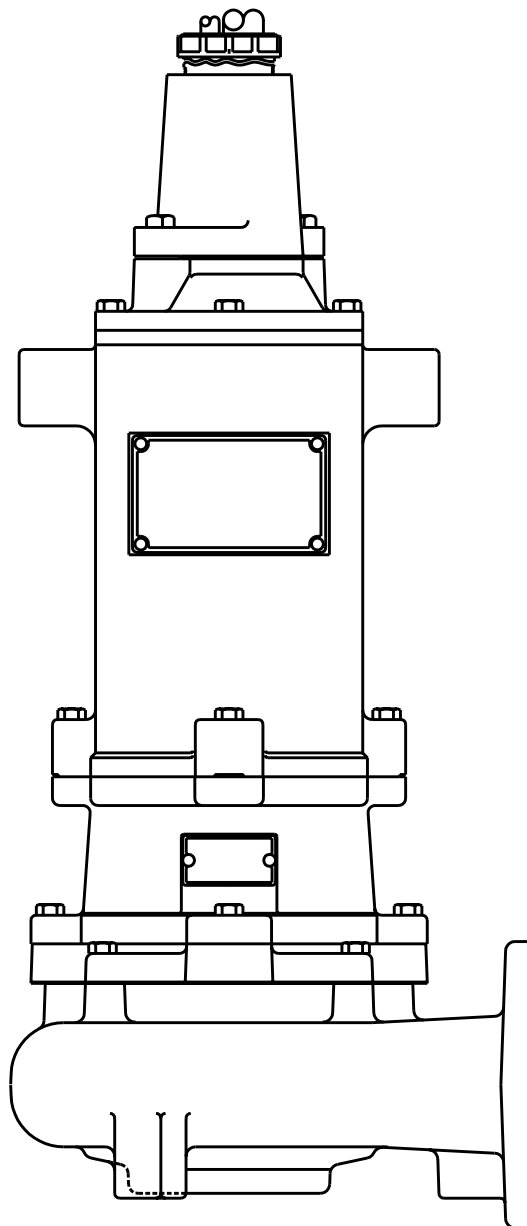

(3VX only)

CAUTION!

Read these safety warnings first before installing, servicing, or operating any pump.

GENERAL

1. Most accidents can be avoided by using **COMMON SENSE**.
2. Read the operation and maintenance instruction manual supplied with the pump.
3. Do not wear loose clothing that can become entangled in the impeller or other moving parts.
4. This pump is designed to handle materials which could cause illness or disease through direct exposure.

Wear adequate protective clothing when working on the pump or piping.

ELECTRICAL

5. To reduce the risk of electrical shock, pump must be properly grounded in accordance with the National Electric Code and all applicable state and local codes and ordinances.
6. To reduce risk of electrical shock, disconnect the pump from the power source before handling or servicing.
7. Any wiring to be done on pumps should be done by a qualified electrician.
8. Never operate a pump with a power cord that has frayed or brittle insulation.
9. Never let cords or plugs lay in water.
10. Never handle connected power cords with wet hands.

PUMPS

11. Pump builds up heat and pressure during operation, allow time for pump to cool before handling or servicing.
12. Only qualified personnel should install, operate or repair pump.
13. Keep clear of suction and discharge openings. **DO NOT** insert fingers in pump with power connected.
14. Do not pump hazardous material not recommended for pump (flammable, caustic, etc.).
15. Make sure lifting handles are securely fastened each time before lifting.
16. Do not lift pump by the power cord.
17. Do not exceed manufacturers recommendation for maximum performance, as this could cause the motor to overheat.
18. Secure the pump in its operating position so it can not tip over, fall or slide.
19. Keep hands and feet away from impeller when power is connected.

20. Submersible non-clog pumps are not approved for use in swimming pools, recreational water installations, decorative fountains or any installation where human contact with the pumped fluid is common.
21. Do not operate pump without safety devices in place.
22. For hazardous locations, use pumps that are listed and classified for such locations.

IMPORTANT! Myers is not responsible for losses, injury or death resulting from a failure to observe these safety precautions, misuse or abuse of pumps or equipment.

GENERAL INFORMATION:

Pump Models: These instructions cover the installation and service of the Myers 3V/3VX series non-clog submersible pumps. The 3VX models are Factory Mutual approved and listed explosion proof for hazardous sewage locations Class 1, Division 1, Group C & D.

Motor HP & Voltages: These non-clog pumps are offered in single or three phase wiring configuration. Voltages will vary according to the application and can be seen in the tables in this manual. All motors are 230 volt, 1 phase and 200, 230, 460, 575 volt, 3 phase, 1750 rpm.

Electrical Controls: All of these pump models must be used with a control panel. Myers built control panels are designed to supply the correct electrical controls, motor starting equipment and include the circuitry for moisture and heat sensors. It is recommended that a Myers built control panel be used so that all warranties apply.

General Construction: The 3V motor construction is designed to meet Factory Mutual requirements for Class 1, Division 1, Group C & D sewage applications. The 3VX models are certified and nameplated with this approval. A cross sectional view of the internal workings of the pumps can be seen on page 6. The motor chamber and seal chamber are filled with a high dielectric type oil for improved lubrication and heat transfer of the bearings and motor. Since the bearings have been designed for 50,000 hours of life, the oil should never require replacement under normal operating conditions. An air space above the oil level in both the seal and motor chambers is provided to allow for the expansion of the oil when at operating temperature. The power and control lines are sealed and strain relieved by grommet in cord

cap, and internally through the use of a dielectric potting resin surrounding the electrical wires. Internal connection wiring diagrams are shown on page 9. All of the pump fasteners and shafts are made from corrosion resistant stainless steel, while the pump castings are made of ASTM A-48 Class 30 cast iron. The wear ring is brass and all impellers are two vane enclosed non-clog design made from ductile iron.

General Installation: Various configurations and methods of plumbing this series of non-clog pumps may be used; however, for ease of installation and service a Myers 3" rail lift-out system is recommended.

Note: If the 3VX explosion proof pumps are used in conjunction with a rail lift-out system, it must be a Factory Mutual approved non-sparking, explosion-proof system. The Myers approved lift-out models are:

3" Lift-Out
SRAX33

If these Guidelines are not followed, the Factory Mutual approval is void.

Explosion Proof Service: These pumps are to be used for handling sewage, wastewater and storm water only. **Do not** use in other hazardous locations. These motors must be repaired and serviced only at Myers Authorized Service Centers or at the Myers factory. Any unauthorized field repair voids warranty and the explosion proof rating.

CAUTION: After the pump is installed and sewage has entered the basin there is "Danger". Sewage water gives off methane and hydrogen sulfide gases, which are poisonous. Never enter a wet well unless the cover is open for a sufficient period of time to allow fresh air into the basin. It is recommended that a man in the basin have a harness on with a rope to the surface, so that he can be pulled out in case of asphyxiation. It is for this reason that Myers recommends using the rail lift-out system so that no service is required inside the basin.

Motor: Each motor is provided with heat sensor thermostats attached directly to the motor windings. The thermostats open if the motor windings see excessive heat and, in turn, open the motor contractor in the control panel, breaking the power to the pump. When the motor is stopped due to an over-heated condition, it will not start until the motor has cooled and the heat sensor reset button is manually

pushed on the front of the Myers control panel. This circuitry is provided in the Myers control panel designs.

The thermostats are made by Texas Instrument Co., Model #9700K, and are set to open at a temperature of 248°F (120°C). The maximum contact rating is 18 amps at 115 VAC and 12 amps at 230 VAC. Motor winding insulation is good for Class F (311°F, 155°C).

Note: Failure to use proper circuitry and to connect the motor overheat protection in the control panel would negate all warranties and Factory Mutual approval.

Motor Seal Failure Warning: The seal chamber is oil filled and provided with moisture sensing probes to detect water leakage through the lower shaft seal. The probes can also detect moisture present in the upper motor housing.

The presence of water energizes a red seal leak warning light at the control panel. This is a warning light only, and does not stop the motor. It indicates a leak has occurred and the pump must be repaired. Normally, this indicates the outboard seal has leaked. Allowing the unit to operate too long after the warning could cause upper seal leakage along with motor failure.

The resistance across the moisture sensing (seal failure) probes, should be checked after a seal leak warning light has lit. This can be done by disconnecting the red and orange control wires from the control panel, and measuring the resistance with an ohm meter between the wires. For a standard, non-explosion proof pump the reading should be 100,000 ohms or greater, and for an explosion proof pump the reading should be above 30,000 ohms. If the measured values are below those indicated above, then the pump may have a lower seal failure and require service.

On the Myers explosion proof control panels the seal leak test switch tests the seal leak circuit continuity. When pushed the seal leak test bulb should light. If the test bulb does not light it means either the wiring circuitry to the seal leak probes has been broken or the bulb has burned out.

Note: Myers built control panels supply the correct circuitry for moisture and heat sensor connections. Failure to install the correct circuitry with proper connection would negate warranty and Factory Mutual approval.

Motor Power Cord, Control Cord and Cord Cap

Assembly: Each motor power cord has 4 conductors - white, black, red and green. For a three phase motor the red, black and white conductors connect to the three line leads, and the green is connected to a good ground. Interchanging any two line leads will reverse the rotation of the motor.

Note: Rotation should be clockwise when observed from the top of the pump. This can be checked by noting which direction the pump torque is up on initial starting. A properly rotating pump will torque counter-clockwise upon start.

The control cable has 5 conductors - black, white, red, orange and green. White and black connect to the heat sensor terminals in the control panels; red and orange connect to the seal failure terminals in the control panel; and the green connects to the ground in the control panel.

The cord cap is epoxy potted. The cord cap provides for a sealed wire connection. This allows the cord cap, with cords, to be removed from the motor. With this arrangement, the cords can be permanently installed in a sealed fitting in the sump. This should be an approved explosion proof junction box for hazardous locations. ***The control and power cables cannot be spliced!*** When the pump is removed for service, the cord cap can stay and be reinstalled when pump is returned.

Note: Each cable has a green ground wire and must be properly grounded per the National Electric Code and local codes.

Electrical Motor Controls: All electrical controls and motor starting equipment should be as specified in these instructions. Consult factory for any acceptable alternates. For hazardous locations the controls and control panel must be installed outside the hazardous area, or approved explosion proof controls that are intrinsically safe must be used.

Junction Box: If a junction box is used in a hazardous location, it must be an explosion proof approved type with explosion proof cord connectors. Wires from the junction box must pass through an explosion proof seal connector.

Level Sensing Controls: Intrinsically safe type float controls are recommended for all applications and required for explosion proof service. An intrinsically safe control panel relay will limit the current and

voltage to the level controls. A Myers control panel can be supplied with this type circuitry.

The float level controls maintain the basin sewage water level by controlling pump turn-on and turn-off levels.

1. The lower turn-offs control should be set so that the pump stops at approximately the top of the pump. Consult the factory for any settings below this point.
2. The upper turn-on control should be set above the lower turn-off control. The exact height between the two controls is determined by the number of pump starts desired and the depth of the basin. A maximum of 10 starts per hour should not be exceeded.
3. The override control is set at a specified height above the upper turn-on control.
4. The alarm control is set about 6" to 12" above the override control.
5. No control should be set above the inlet invert.

Electrical Connections: All electrical wiring must be in accordance with local code and only qualified electricians should make the installations. Complete wiring diagrams are included for use in making the installation. All wires should be checked for shorts to ground with an ohmmeter or megger after the connections are made. This is important, as one grounded wire can cause failure of the pump, control panel or personal injury.

Pump: The fluid end of the pump is field serviceable and can be disassembled in case of wear, damage, plugging or outboard seal failure. The following will describe the disassembly and reassembly process.

WARNING: Disconnect pump from power source before servicing or handling pump.

Disassembly

1. With the pump located in a secure place, remove the bolts fastening the seal housing to the volute. The motor and impeller can now be removed as a unit.
2. Lay the unit down on its side. If the lower seal is to be removed, it is recommended that the oil in the seal chamber be drained. This can be done by removing the lower seal chamber plug and draining the oil into a holding container.

3. To remove the impeller. Using a proper wrench, the impeller retaining bolt and washer must be removed. This may require a piece of wood placed between the vanes to keep the impeller from rotating while removing the bolt. Once the bolt has been removed, tap lightly with a hammer around the outside diameter of the impeller to loosen from shaft and key. After removing impeller, the seal retainer needs to be removed to expose seal.

Caution: The impeller is large and heavy and will need to be supported.

4. If the lower seal needs removed, first remove the compression spring that rides between the impeller and the seal assembly. Next take a pair of screwdrivers and remove the compression ring that surrounds the rubber bellows on the rotating portion of the seal assembly. Again using the screwdrivers, pry the remaining portion of the rotating seal assembly off of the shaft. The ceramic stationary can be removed by placing a screwdriver between the rubber and the ceramic face, and then prying, working around the entire diameter. Note, these parts should be discarded and a new seal assembly installed.
5. If the oil in the seal chamber was drained, examine the contents to determine if the upper seal has been damaged. Signs of grit or other abrasive material may indicate that the upper seal has also been damaged. Pressurizing the motor housing assembly between 7 and 10 psi and observing any drop in pressure will indicate if the upper seal is functioning properly.

Note: Upper seal repairs must be done at a Myers Authorized Service Center or at the Myers factory. Any unauthorized field repair voids warranty and the explosion proof approval on the Factory Mutual listed pump.

6. The wear ring can be removed from the volute for repair or replacement. First remove the retaining screws from the wear ring. With a soft mallet the wear ring can be tapped out of the volute case.

Reassembly

1. Remove the ceramic portion of the new seal from the package. Brush new dielectric oil or glycerine around the rubber portion of the stationary assembly and into the pocket in the seal housing. Note, keep the oil off the seal face. Without scratching the seal face, press the ceramic stationary portion into the seal housing. A piece of PVC pipe that fits onto the face of the seal works well for installation. With clean cloth, lightly wipe the face of the seal surface to make sure it is dirt free. Remove the rotating portion of the seal from the package and lubricate the inside diameter of the rubber bellows and the outside diameter of the shaft. Place the seal over the shaft (make sure the key is removed). Evenly press on the body of the rotational assembly and slide it down the shaft until the seal faces meet. A PVC pipe with the inside diameter slightly larger than the shaft diameter can work well to press the rotational assembly into position. Once the seal assembly is in position, place the spring over the register on the rotational portion of the seal.
2. Before placing impeller on shaft, the seal spring retainer should be placed on shaft with stepped end towards seal spring. Position the key into the seat in the shaft. Align the impeller onto the shaft, making sure that the seal spring is registered properly onto the back side of the impeller. Insert the bolt and washer assembly into the shaft and tighten to 43 ft.-lbs.
3. Fill the seal chamber with new dielectric oil. An air gap of 10-15% volume must be left for the expansion of the oil when it is at operating temperature.
4. The brass wear ring can be aligned with the retaining holes and tapped into place with a soft mallet. The proper Loctite should be applied to the bolts. Install and tighten.
5. The motor and impeller assembly can be installed into the volute. Make sure that the impeller aligns properly with the volute. Install the volute retaining bolts and tighten.
6. Air tends to trap in the pump case when water rises in the sump or when the pump is lowered into the water after service. To vent off this air, a small hole is drilled into the volute casting. **Be sure this vent hole is clean after any service work on pump.** Air venting is not a problem after initial start.

3V/3VX Pumps

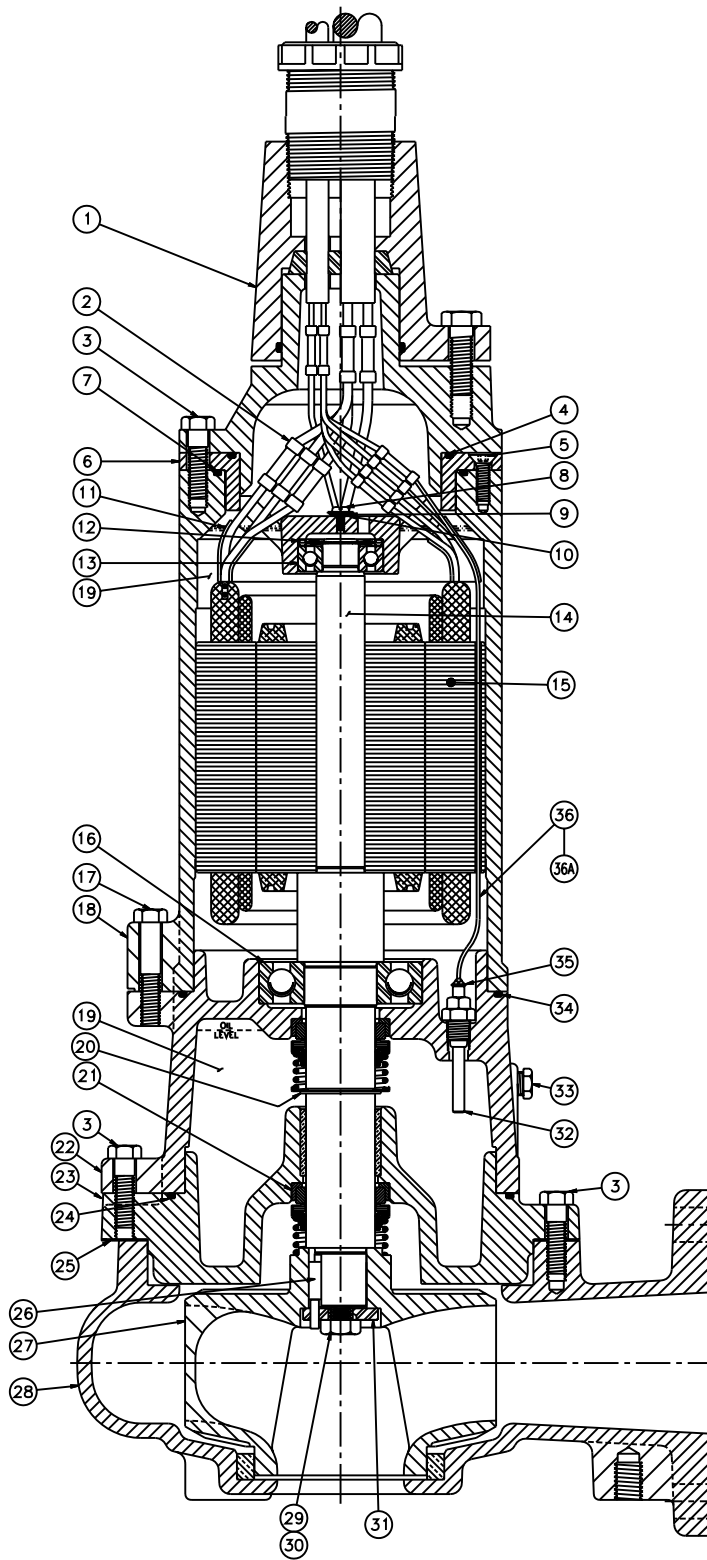

3V/3VX PARTS LIST

REF. NO.	DESCRIPTION	NO. REQ'D.	PART NUMBER
1	Cord, Cap with Wires	1	22569B010
2	Connector	3	12672A003
3	Screw, Hex. Hd., 7/16" x 1-1/2" long	12	19102A006
4	O-ring, 4-7/8" x 4-5/8 1/8" thick	1	05876A123
5	Screw, Mach; 5/16" x 1" long	2	07597A017
6	Housing, Upper Bearing	1	22590B000
7	O-ring; 5-1/2" x 5-1/4" x 1/8" thick	1	05876A112
8	Screw, Mach; #10 x 3/8" long	1	05434A043
9	Washer, Flat	1	05030A126
10	Washer, Lock	1	06107A015
11	Tube, Plastic	2	10649A116
12	Washer, Spring	2	19331A006
13	Bearing, Upper	1	08565A022
14	Rotor w/Shaft	1	See Chart
	Shaft Only		22881C101
15	Stator	1	See Chart
16	Bearing, Lower	1	08565A027
17	Screw, Hex. Hd., 7/16" x 2-1/4" long	4	19102A023
18	Housing, Motor	1	22571D000
19	Oil, Transformer	1.6 gal.	11009A006K
20	Ring, Retaining	1	12558A018
21	Seal, Shaft	2	22922A000
22	Housing, Upper Seal	1	22709D010
23	Housing, Lower Seal	1	22710C000
24	O-ring; 7-1/2" x 7-1/4" x 1/8" thick	1	05876A127
25	Gasket, Vellumoid	1	05231A079
26	Key	1	05818A066
27	Impeller, O.D. as specified	1	22946C550
28	Case, Volute w/Wear Ring	1	22945D050
29	Screw, Hex. Hd., 1/2" x 1-1/4" long	1	19103A052
30	Sealant, Loctite	1	14550A009
31	Washer, Impeller Retaining	1	23609A002
32	Probe, Seal	2	25343A100
33	Plug, Pipe	2	05022A054
34	O-ring; 7" x 6-3/4" x 1/8" thick	1	05876A114
35	Screw, Mach., #6 x	2	05434A025
36	Wire, Electrode	2	22578A100
36A	Resistor (explosion-proof only) (Secured between item 35)	1	22912A000

PUMP CATALOG NO.	ROTOR w/SHAFT	STATOR ONLY	HOUSING w/STATOR
3V/3VX10M4-21 3V/3VX10M4-03 3V/3VX10M4-23 3V/3VX10M4-43 3V/3VX10M4-53	22875C108 22875C115 22875C115 22875C115 22875C115	24407C211 24407C212 24407C213 24407C213 24407C214	22571D500K 22571D505K 22571D510K 22571D510K 22571D515K
3V/3VX15M4-21 3V/3VX15M4-03 3V/3VX15M4-23 3V/3VX15M4-43 3V/3VX15M4-53	22875C108 22875C115 22875C115 22875C115 22875C115	24407C211 24407C212 24407C213 24407C213 24407C214	22571D500K 22571D505K 22571D510K 22571D510K 22571D515K
3V/3VX20M4-21 3V/3VX20M4-03 3V/3VX20M4-23 3V/3VX20M4-43 3V/3VX20M4-53	22875C110 22875C107 22875C107 22875C107 22875C107	24407C215 24407C216 24407C217 24407C217 24407C218	22571D520K 22571D525K 22571D530K 22571D530K 22571D535K
3V/3VX30M4-21 3V/3VX30M4-03 3V/3VX30M4-23 3V/3VX30M4-43 3V/3VX30M4-53	22875C105 22875C105 22875C105 22875C105 22875C105	24407C219 24407C201 24407C202 24407C202 24407C203	22571D540K 22571D545K 22571D550K 22571D550K 22571D555K
3V/3VX50M4-21 3V/3VX50M4-03 3V/3VX50M4-23 3V/3VX50M4-43 3V/3VX50M4-53	22875C105 22875C105 22875C105 22875C105 22875C105	24407C219 24407C201 24407C202 24407C202 24407C203	22571D540K 22571D545K 22571D550K 22571D550K 22571D555K

WIRING DIAGRAMS

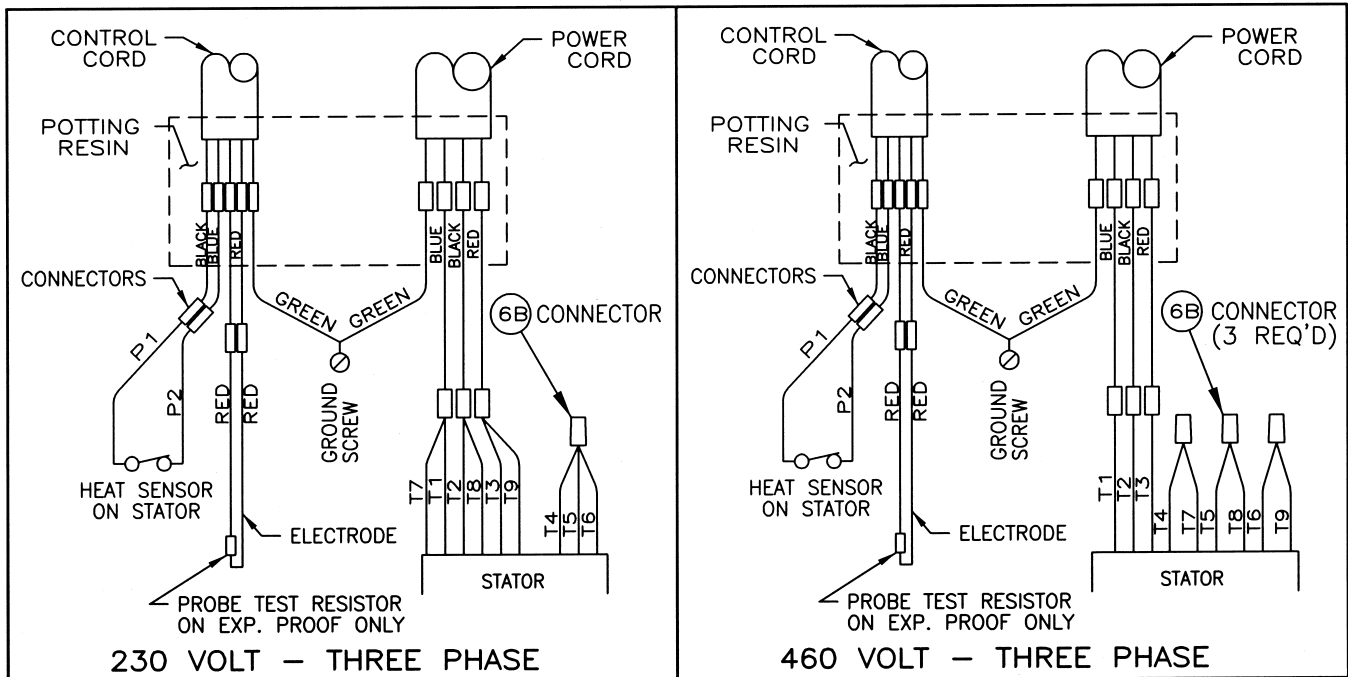
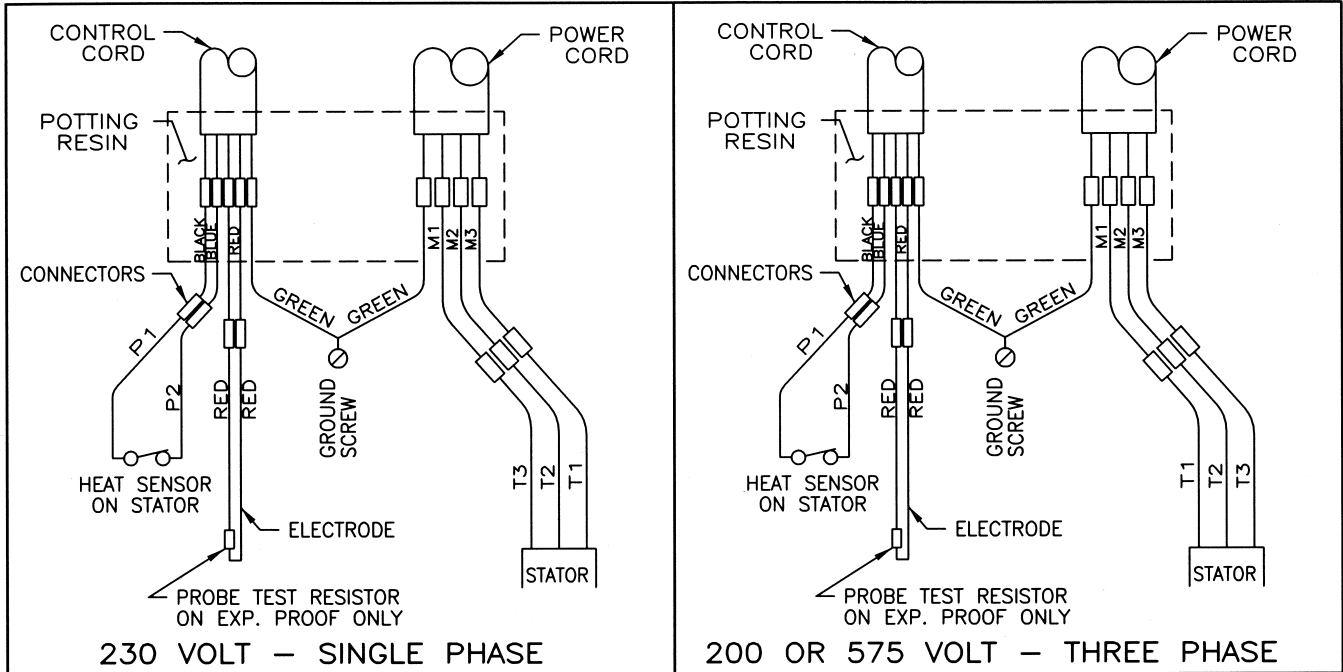

CHECK LIST IF PUMP DOES NOT OPERATE PROPERLY

Checking for Moisture in Motor: Use an ohmmeter or a megger and set on highest scale. Readings on the large power cord between any of the conductors red, black or white to the green conductor or to the motor housing should be greater than 1,000,000 ohms (1 megaohm). A motor will probably run with a lower reading, but if the pump is out of service and the value of the reading is below 1,000,000 ohms (1 megaohm), the motor housing and stator should be removed and baked in a drying oven at 220°F. This service work should only be done at an authorized service station. Note, readings should be taken with line leads disconnected from the control panel.

Resistance of Windings: Every motor winding has a fixed resistance. The windings must check close to the values given in the tables to operate properly. Verification of the proper wiring of a dual voltage motor can also be checked by measuring the motor winding resistance. See the motor electrical data chart. Use an ohmmeter and set to the one ohm scale. Read the resistance with the motor leads disconnected from the pump control panel.

CONDITION

PROBABLE CAUSE

Red light comes on at control box.

This indicates some water has leaked past the lower seal and has entered the seal chamber and made contact with the electrode probe. Pump must be removed for replacement of lower seal. This preventative repair will save an expensive motor.

Overload trips at control box and alarm buzzer or flashing red light comes on due to high water level in basin.

1. Push in on red reset button to reset overload. If overload trips again after short run, pump has some damage and must be removed from basin for checking.
2. Trouble may be from clogged impeller causing motor to overload or could be from failed motor.
3. Trouble may be from faulty component in control box. Always check control box before removing pump.

Yellow run light stays on continuously.

1. Indicates H-O-A switch may be in the hand position.
2. Level control switch may have failed causing pump to continue to operate when water is below lower control.
3. Impeller may be partially clogged causing pump to operate at very reduced capacity.
4. Gate valve or check valve may be clogged causing low pump flow.
5. Pump may be air locked.

Circuit breaker trips.

1. Reset breaker by pushing completely down on handle then back to ON position. If breaker trips again in few seconds it indicates excessive load probably caused by a short in the motor or control box. Check out instructions given with control box before pulling pump.
 2. If this condition happens after an electrical storm, motor or control box may be damaged by lightning.
 3. Resistance reading of the motor with lead wires disconnected from the control box can determine if trouble is in motor or control box.
-

CONDITION

Pump is noisy and pump rate is low.

Grease and solids have accumulated around pump and will not pump out of basin.

IMPORTANT - Pump should be thoroughly cleaned of trash and deposits before starting disassembly operations.

CAUTION - DISCONNECT ALL POWER AND CONTROL WIRES TO MOTOR AT CONTROL PANEL BEFORE STARTING DISASSEMBLY OPERATIONS. NEVER RELY ON OPENING CIRCUIT BREAKER ONLY.

PROBABLE CAUSE

1. Impeller may be partially clogged with some foreign objects causing noise and overload on the motor.
2. Impeller may be rubbing on wear ring due to bent shaft or misalignment.
3. Pump may be operating too close to shut-off. Check head.

-
1. Lower control switch may be set too high.
 2. Run pump on hand operation for several minutes with small amount of water running into basin to clean out solids and grease. This allows pump to break suction and surge which will break up the solids. If level switch is set properly this condition generally will not occur.
 3. Trash and grease may have accumulated around floats causing pump to operate erratically.
-

CAP SCREW	TORQUE VALUE
3/8-16	20 ft.-lbs.
1/2-13	43 ft.-lbs.
5/8-11	93 ft.-lbs.
3/4-10	128 ft.-lbs.
7/8-14	193 ft.-lbs.

3V/3VX Pump Performance

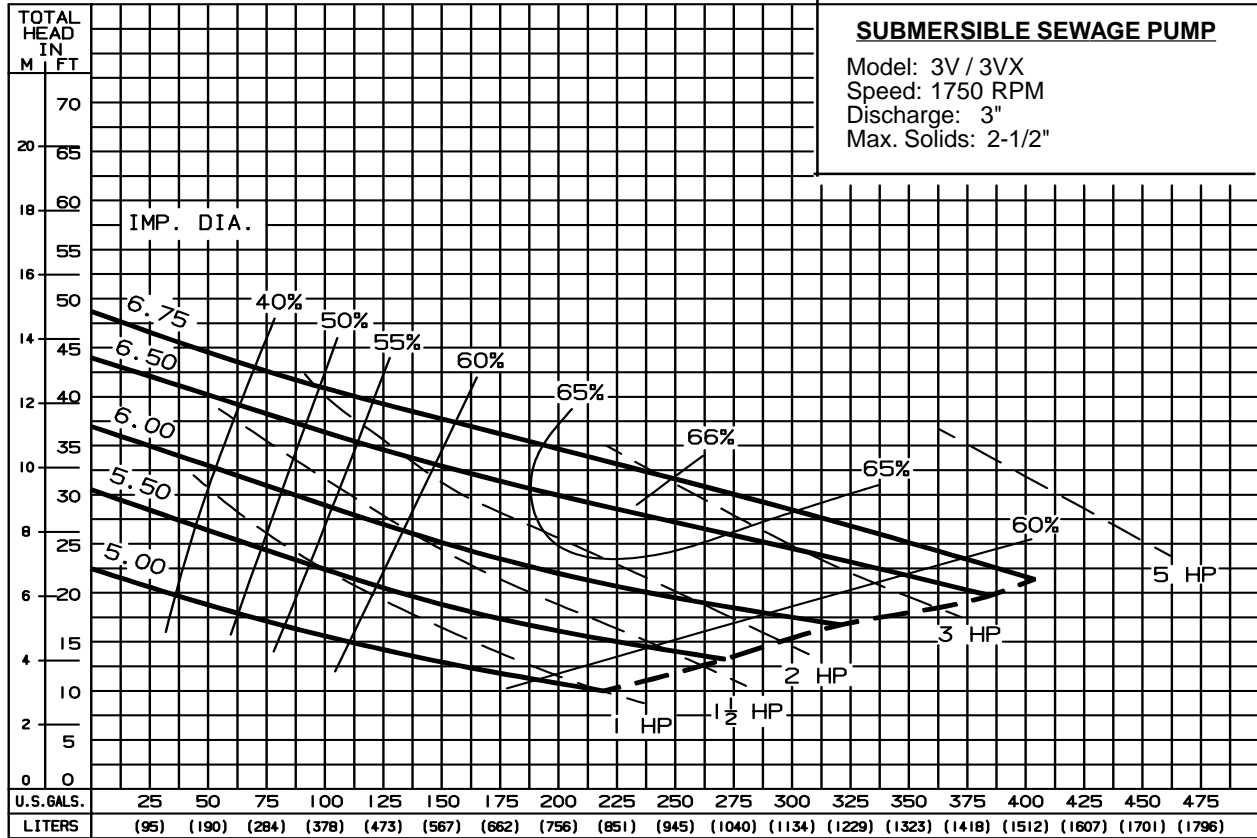

Pump performance is based on clear water (1.0 specific gravity @ 68°F) and pump fluid end (hydraulic) efficiency. Motor data based on 40°C ambient temperature.

Available Models		Motor Electrical Data											
Standard	HP	Volts	Phase	Hertz	Start Amps	Run Amps	Service Factor Amps	Run KW	Service Factor KW	Start KVA	Run KVA	NEC Code Letter	Service Factor
3V/3VX10M4-21	1	230	1	60	50	8	10	1.2	1.6	11.5	1.8	J	1.2
3V/3VX10M4-03	1	200	3	60	36	5.4	6.2	1.3	1.5	12.5	1.8	K	1.2
3V/3VX10M4-23	1	230	3	60	32	4.5	5.4	1.2	1.5	12.7	1.8	K	1.2
3V/3VX10M4-43	1	460	3	60	19	2.3	2.7	1.2	1.5	15.1	1.8	M	1.2
3V/3VX10M4-53	1	575	3	60	13	1.8	2.2	1.2	1.5	12.7	1.8	J	1.2
3V/3VX15M4-21	1.5	230	1	60	50	10	12	1.6	1.9	11.5	2.3	J	1.2
3V/3VX15M4-03	1.5	200	3	60	36	6.6	8	1.6	1.9	12.5	2.2	K	1.2
3V/3VX15M4-23	1.5	230	3	60	32	5.5	7	1.6	1.9	12.7	2.2	K	1.2
3V/3VX15M4-43	1.5	460	3	60	19	2.8	3.5	1.6	1.9	15.1	2.2	M	1.2
3V/3VX15M4-53	1.5	575	3	60	13	2.2	2.8	1.6	1.9	12.7	2.2	K	1.2
3V/3VX20M4-01	2	200	1	60	78	15	18	2.1	2.5	15.6	3.0	J	1.2
3V/3VX20M4-21	2	230	1	60	64	12	14.4	1.9	2.3	14.7	2.8	J	1.2
3V/3VX20M4-03	2	200	3	60	44	8.4	9.8	1.8	2.3	15.2	2.8	J	1.2
3V/3VX20M4-23	2	230	3	60	40	7	8.6	1.8	2.3	15.9	2.8	J	1.2
3V/3VX20M4-43	2	460	3	60	23	3.5	4.3	1.8	2.3	18.3	2.8	L	1.2
3V/3VX20M4-53	2	575	3	60	16	2.8	3.4	1.8	2.3	15.9	2.8	J	1.2
3V/3VX30M4-21	3	230	1	60	101	21	26	2.5	3.0	23.2	4.8	J	1.2
3V/3VX30M4-03	3	200	3	60	66	15	18	3.5	4.5	22.8	5.2	J	1.2
3V/3VX30M4-23	3	230	3	60	58	12	15.6	3.5	4.5	23.1	4.8	J	1.2
3V/3VX30M4-43	3	460	3	60	29	6	7.8	3.5	4.5	23.1	4.8	J	1.2
3V/3VX30M4-53	3	575	3	60	21	5	6	3.5	4.5	20.9	5.0	H	1.2
3V/3VX50M4-21	5	230	1	60	101	34	34	4.0	6.0	23.2	7.8	J	1.0
3V/3VX50M4-03	5	200	3	60	66	24	24	6.0	6.0	22.8	8.3	J	1.0
3V/3VX50M4-23	5	230	3	60	58	21	21	6.0	6.0	23.1	8.3	J	1.0
3V/3VX50M4-43	5	460	3	60	29	10.5	10.5	6.0	6.0	32.1	8.3	J	1.0
3V/3VX50M4-53	5	575	3	60	21	8.4	8.4	6.0	6.0	20.9	8.3	H	1.0

DIMENSIONS

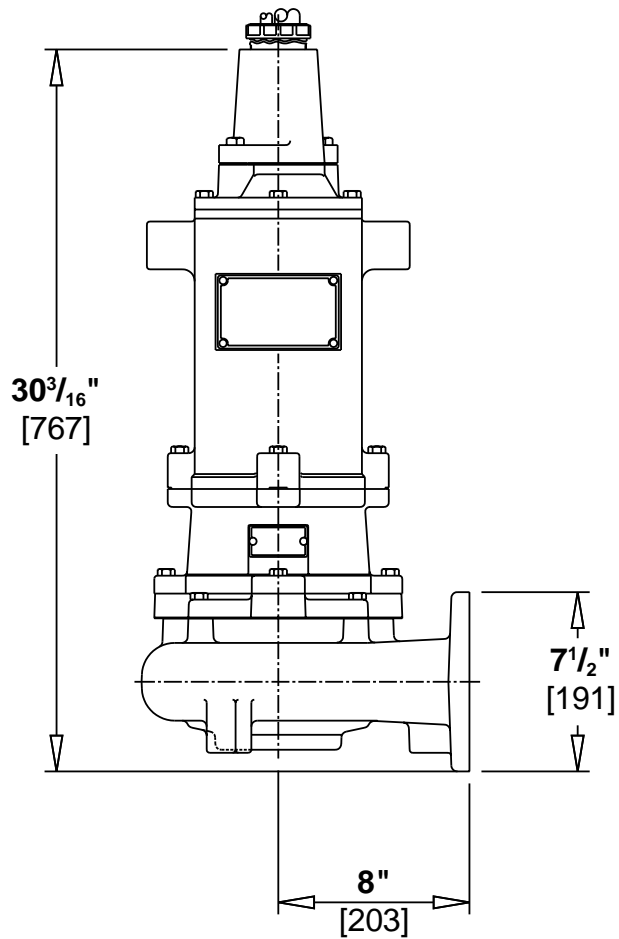
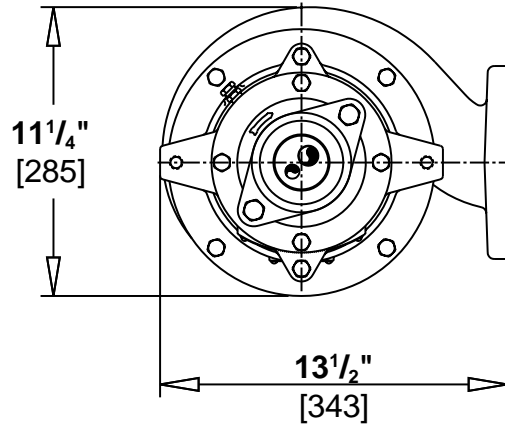

Myers[®]
Pentair Pump Group

F. E. Myers, 1101 Myers Parkway, Ashland, Ohio 44805-1969
419/289-1144, FAX: 419/289-6658, www.femyers.com

Myers (Canada), 269 Trillium Drive, Kitchener, Ontario N2G 4W5
519/748-5470, FAX: 519/748-2553