

Myers®

Pentair Pump Group

MRG20 Grinder Pump

Installation & Service Manual
with Parts List

2 HP Grinder Pump for Residential Applications

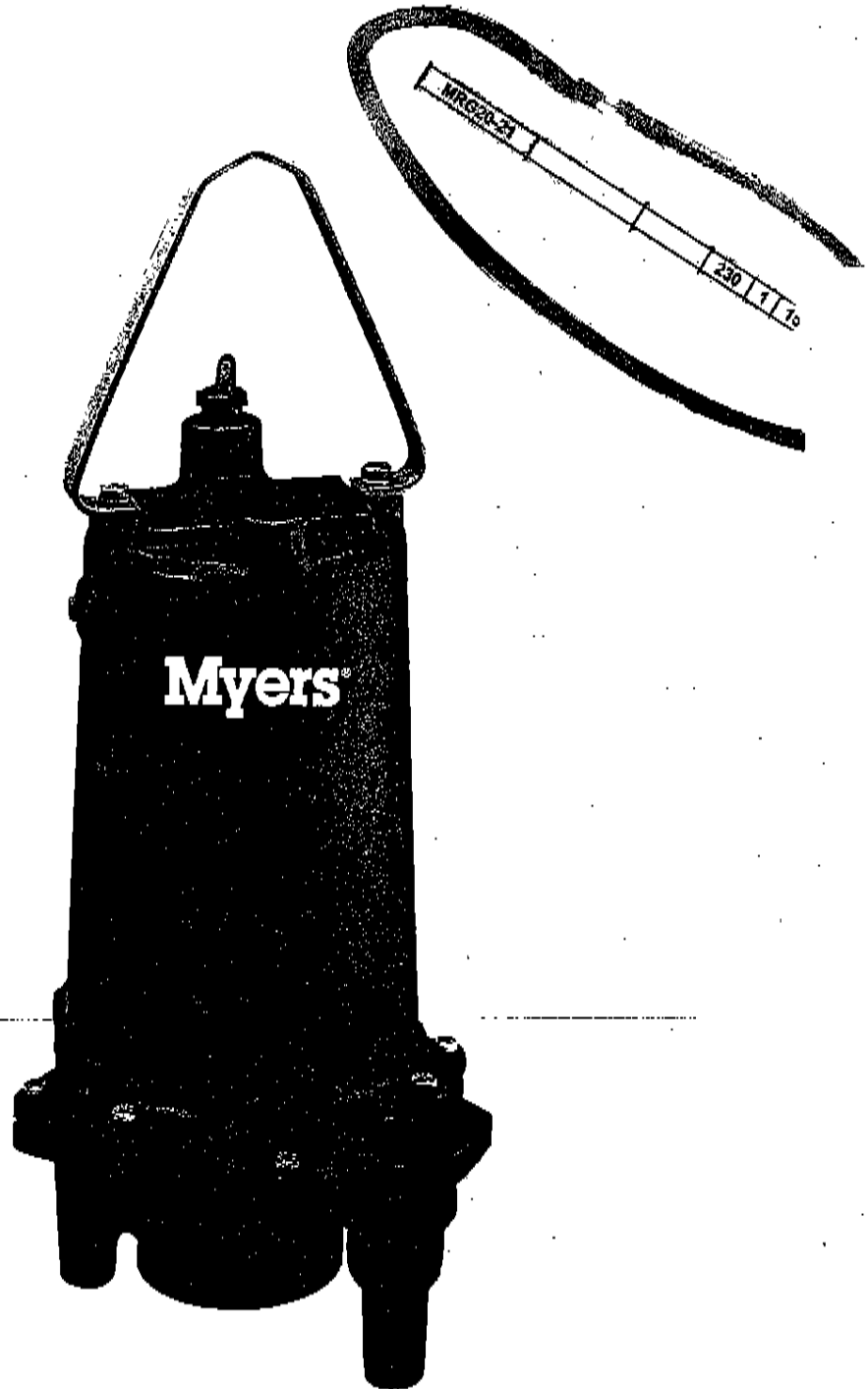

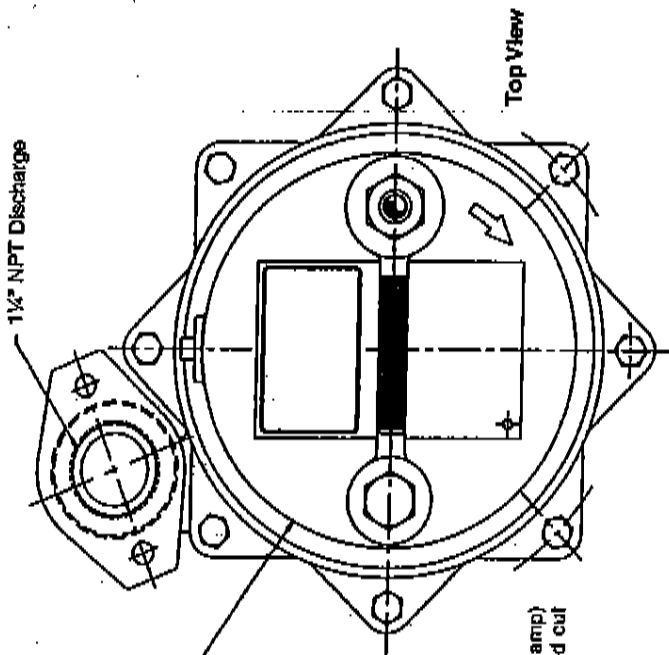

1 1/2" NPT Discharge

Motor Housing must be positioned as shown

Top View

NOTE: On Item 26 (clamp) once clamp is tightened cut off excess strap.

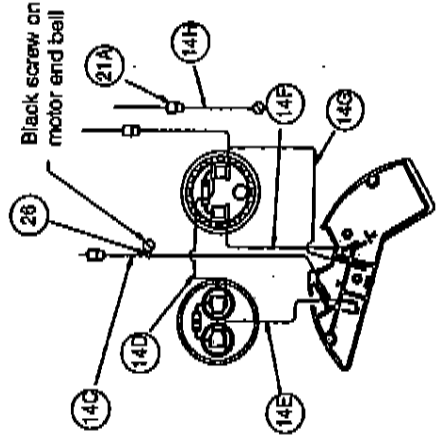

Black screw on motor end ball

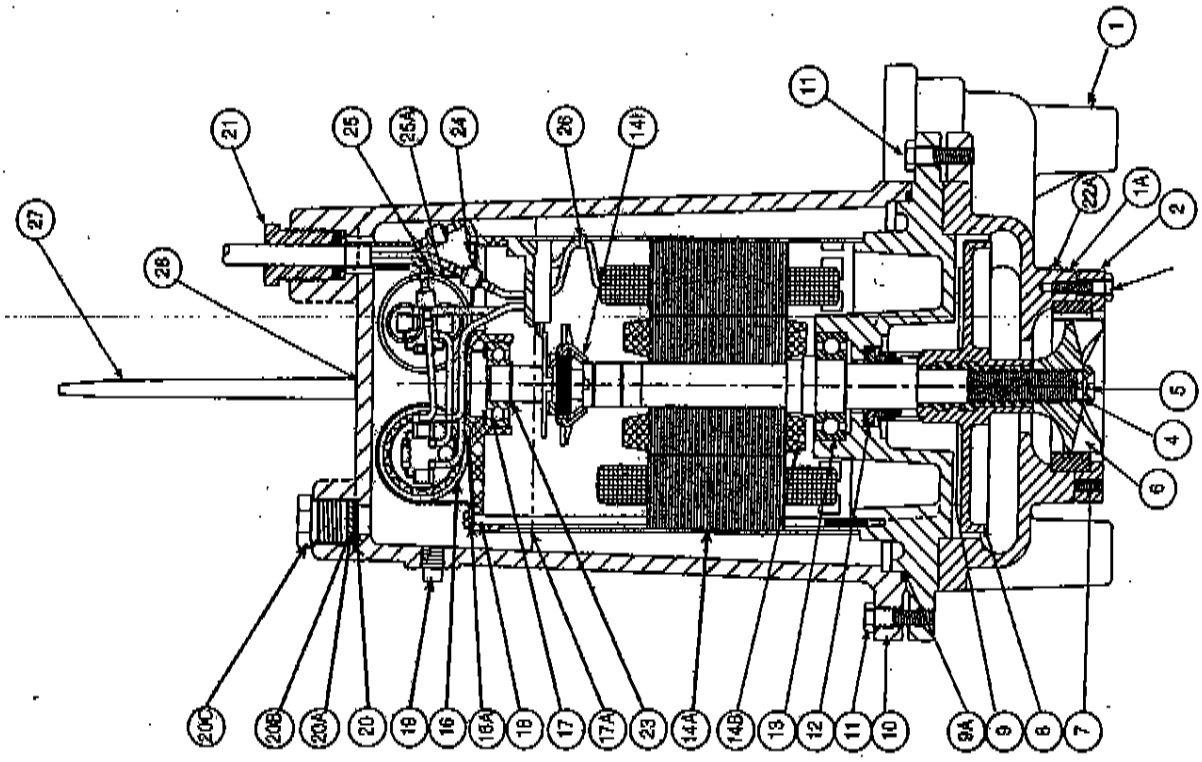

Ref No.	Part No.	Description
1	26433D002	Case, volute
2	21584B000	Flange, w/shredding ring
3	19099A012	Screw, cap 1/4" x 1" long, SST (3 req'd)
4	21583B000	Retainer, impeller, SST
5	07597A018	Screw, flat head, 1/4" x 3/4" long
5A	14550A001	Sealant, Loctite grade 271
6	21582B000	Impeller, grinding
7	05013A039	Screw, set 1/4" x 3/8" long (2 req'd)
8	26434C010	Impeller, pump plastic
8	26434C000	Impeller, cast iron (optional)
9	26430D001	Plate, seal/bearing
9A	05014A181	Gasket, tetraseal 7" x 6-3/4" x 1/8"
10	145890022	Housing, motor
11	19100A012	Screw, cap, 5/16" x 1-1/4" long (8 req'd)
12	21576A010	Seal, 7/8" shaft
13	08565A018	Bearing, lower
14A	26466C101	Stator, w/shell, 2 hp, 230v, 1 ph
14B	26466C002	Rotor, w/shaft
14C	09859A827	Wire, w/term., black, 9" long
14D	09859A828	Wire, w/term., black 4-1/2" long
14E	09859A829	Wire, w/term., yellow, 4" long
14F	09859A830	Wire, w/term., red, 3" long
14G	09859A831	Wire, w/term., white
14H	09859A832	Wire, w/term., green, 6" long
14I	24481A008	Switch, mechanical
16	12141A015	Capacitor, start with resistor
16A	20333A001	Clip, Capacitor
17	08565A013	Bearing, upper
17A	42558A680	Ring, retaining <i>1/8" ID HOOLE replaced</i>
18	19331A005	Washer, spring finger
19	05022A009	Plug, pipe 1/4 NPT
20	05030A235	Washer, SST, 3/32" thick
20A	05014A189	Gasket, rubber
20B	05030A234	Washer, SST, 1/32" thick
20C	25341A002	Nut, solid
21	25338B001	Cord, power
22A		
23	24709110000	Oil, transformer
24	21813B145	Switch, float
25	23838A010	Capacitor, run with resistor
25A	20333A004	Clip, capacitor
26	17190A004	Clamp
27	25371B006	Handle
28	19101A003	Screw Cap

UL AND CSA APPROVAL

UL and CSA approved. Myers is a SSPMA certified pump member.

USAGE

The MRG20 is a submersible wastewater grinder pump designed specifically for individual residential applications. The pumps are to be used for domestic sewage only and are not to be used for pumping commercial or industrial sewage such as motels, schools, apartments, factories, etc. **THIS PUMP IS NOT FOR USE IN HAZARDOUS LOCATIONS!**

INSTRUCTIONS

These instructions cover only the grinder pump unit. Separate instructions for the basin system are included with the basin. Pump is not to be disassembled except at a certified service station or at the Myers factory. **WARRANTY IS VOID IF PUMP IS TAKEN APART FOR ANY REASON EXCEPT TO REPLACE GRINDER IMPELLER, VOLUTE CASE/GRINDING RING.**

INSPECTING PUMP

Before making any piping or electrical connections, check the pump for shipping damage or cracks. Using a flat screwdriver placed in the slot on the shaft end, turn shaft and Impellers to be sure they are free. **DO NOT TURN IMPELLER WITH FINGERS AS EDGES ARE SHARP.**



CAUTION! NEVER WORK ON THE UNIT WITHOUT DISCONNECTING THE ELECTRICAL POWER CORD.

POWER SUPPLY

The MRG20 grinder pump should only be connected to a 230 volt, single phase, 60 Hz power source. The pump will draw approximately 9.1 amperes at minimum flow and 15.0 full load amperes. Locked rotor current is 51.9 amperes. The pump must be connected to a grounded power socket. **DO NOT** cut off the ground pin from the power cord plug.

POWER CORD

A 20 foot power cord is attached to the grinder pump via three insulated quick-disconnect terminals. To replace a cord simply unscrew (turn counterclockwise) cord nut from top of motor housing. Once cord nut is completely loosened from housing, gently pull cord upwards away from housing. While cord is being pulled, it may be necessary to shift cord leads back and forth to guide the insulated terminals through the hole in the motor housing. Once the terminals have cleared the hole, gently pull cord until terminals are completely outside of motor housing. Then simply disconnect terminals to remove cord.

To install new cord, reconnect terminals (black to black, white to white, green to green), and guide terminals back through hole in motor housing. Once terminals have passed through the hole, retighten the cord nut into housing. Tighten nut firmly but do not over tighten.

The power cord should be replaced if it has been damaged in any way or the cord jacket has become brittle with age.

MOTOR TYPE

The MRG20 grinder pump contains a 3/4 frame, 2 HP, single phase, 60 Hz, 3450 R.P.M., capacitor start - capacitor run motor with Class F insulation and built-in on-winding overload protection. Motor has upper and lower ball bearings, and is oil-cooled and lubricated. Resistance at motor leads is 1.8 ohms.

CAUTION: THE MRG20 GRINDER PUMP SHOULD NEVER BE WORKED ON WITHOUT FIRST DISCONNECTING THE POWER CORD.

OIL TYPE

The motor housing contains dielectric transformer oil to provide good heat transfer and lubrication of ball bearings, no other lubrication is required. Oil level may be checked by removing the nut (item 20C) and washers from the top of the motor housing. The oil level should be 3-7/8" from the boss (see figure 1) with pump setting vertically. **Do not over fill with oil.** Only dielectric transformer oil obtained from a Myers authorized service center should be used.

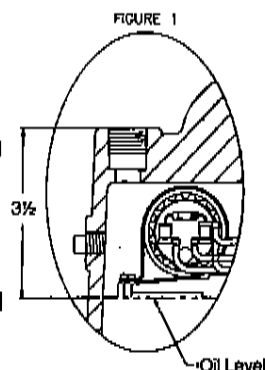

Ref No.	Part No.	Description
24	21813B146	Switch, float

PUMP SWITCH INSTALLATION INSTRUCTIONS

NOTE: In accordance to third party approval, pump must be submerged a minimum of 8½" from bottom of the legs on volute case during operation.

Mounting the Switch

1. Determine pumping range for installation (see Figures A and B). Do not tether less than 3.5 inches (9 cm) from pipe.
2. Tighten strap around discharge pipe keeping switch cable between strap and pipe to prevent slippage (see Figure C).
3. Space small ties at least 1 inch (2.5 cm) apart (see Figure C). To readjust ties, press small tie tabs down.
4. To lock releasable tab, run remaining strap between tab and head. Tuck strap back through head (see Figure C).

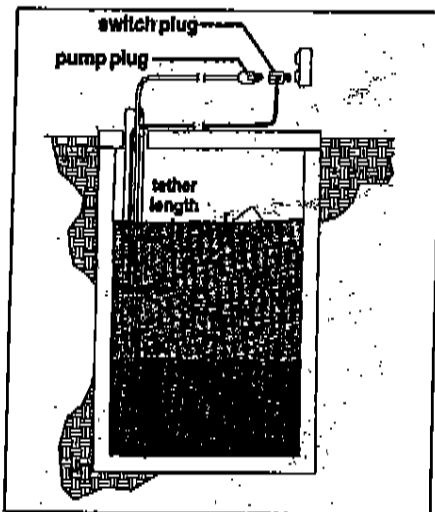

Fig. A

Piggy-Back Plug Install

- ▲ Electrical outlet must not be located in pump chamber.
 - ▲ Electrical outlet voltage, piggyback plug voltage, and pump voltage must match.
1. Follow steps 1 through 4 of "Mounting The Switch."
 2. Insert switch's piggy-back plug into outlet.
 3. Plug pump into piggy-back plug (see Figure A).
 4. Check installation. Allow system to cycle to insure proper operation.

Determining Pumping Range in Inches (1 inch = 2.5 cm)				
tether length	3.5	6	14	22
pumping range	7	10	22	33

Use only as a guide. Pumping ranges are based on testing in non-turbulent conditions. Range may vary due to water temperature and cord shape. Note: As the tether length increases, so does the variance of the pumping range.

Fig. B

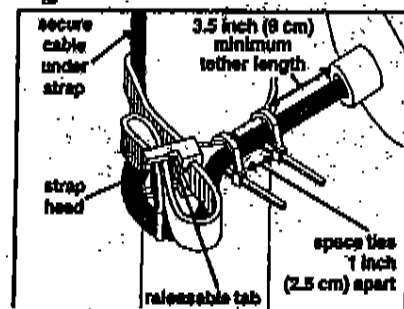
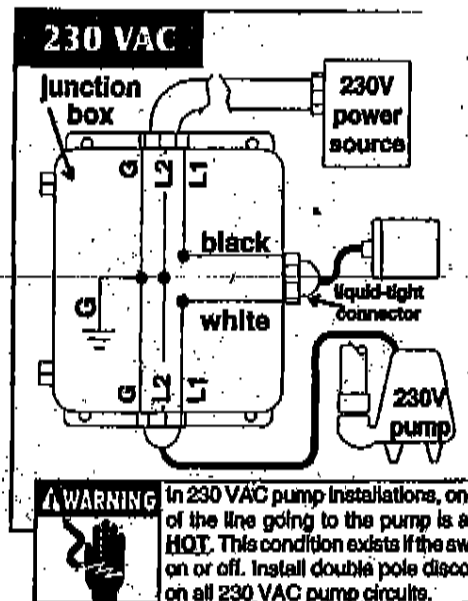

Fig. C

Direct Wire Install

1. Follow steps 1 through 4 of "Mounting The Switch"
2. Wire switch as shown below.
3. Check installation. Allow system to cycle to insure proper operation.



SAFETY WARNINGS

▲ WARNING! Risk of electrical shock. Pumps are supplied with a grounding conductor and grounding-type attachment plug on the power cord. To reduce the risk of electrical shock, be certain that it is connected only to properly grounded, grounding-type receptacle. **DO NOT** cut off ground pin or use an adapter fitting.

DO NOT use an extension cord with this pump. Entire plug may be cut off if a control panel is used. When wiring this pump follow all local electrical, safety codes and ordinances as well as most recent National Electric Code (NEC-ANSI/NFPA).

The MRG20 grinder pumps have a GROUND WIRE that is connected to a screw in the metal motor housing. This wire goes to the receptacle or control box which must be connected to a good outside GROUND such as a metal water pipe or GROUND STAKE driven at least 8 feet into the ground.

DISMANTLING PUMP FOR REPLACEMENT PARTS

Before dismantling pump for replacement parts, clean pump thoroughly. Knock off all scale and deposits. Use sandblast if possible. Submerge complete unit in Clorox solution for one hour before taking apart.

REPLACING GRINDER IMPELLER AND GRINDER SHREDDING RING

This is the only disassembly operation allowed in the field. All other repairs must be done at the factory or at an authorized service station.

STANDARD TOOLS REQUIRED:

1. Allen head socket set.
2. Standard socket wrench set.
3. Set of open end wrenches.
4. Plastic hammer.
5. Vise grip pliers.
6. Large screwdriver with heavy handle.
7. Three-cornered file.

IMPORTANT: Pump should be thoroughly cleaned of trash and deposits before starting disassembly operations.

▲ CAUTION! DISCONNECT ALL POWER AND CONTROL WIRES TO MOTOR AT CONTROL PANEL BEFORE STARTING DISASSEMBLY OPERATIONS. NEVER RELY ON OPENING CIRCUIT BREAKER ONLY.



DISASSEMBLY OF SHREDDING RING AND GRINDER IMPELLER

1. Remove three screws from grinder ring flange. Grinder ring is pressed into flange for easy removal.
2. Using allen head socket wrench thread two screws

into tapped back-off holes in flange evenly tighten screws to guide grinding ring out of pump volute case.

3. Hold grinder impeller by prying against impeller cutting bar and remove cap screw from end of shaft.



4. Use large screwdriver in slot in end of shaft and bump on cutter vane with plastic hammer. Bump in counterclockwise direction as thread is right hand. It may take several bumps to loosen impeller.

If impeller cannot be loosened it will be necessary to take unit to service station for service. **DO NOT CONTINUE TO POUND ON IMPELLER AS IMPELLER AND SHAFT MAY BE DAMAGED.**

5. If impeller comes off easily, clean up and replace if worn.
6. Be sure pump impeller has not loosened when grinder impeller is removed. This can be checked on reassembly of grinder impeller and shredding ring. Tips of impeller cutter vanes should extend about 1/8" below bottom of shredding ring. If distance is more, it means the pump impeller has loosened, and if it is less, it means the shredding ring is not properly seated.

If the pump impeller has loosened, remove grinder impeller and shredding ring as described above and remove bolts from volute case and remove case. Plastic hammer can be used to bump on casing discharge to loosen. Place gasket in oil to prevent drying out. **DO NOT** loosen the pump impeller further -- it is the seat for the seal spring.

7. After case is removed, wrap emery paper around shaft and hold with vice grip pliers. Use cloth on impeller and screw up against shoulder. Now pump can be reassembled.
8. Clean all threads with wire brush and file, smooth any threads that may have been nicked.
9. Use Never-Seeze or other graphite compound on threads before replacing grinding impeller.
10. Be sure cap screw in bottom of shaft is tight. Hold impeller with a screwdriver between cutter bar and teeth of shredding ring while tightening cap screw.
11. Be sure impeller turns free by hand after reassembly. Some drag will occur due to the seal, but there should be no binding or tight spots when turning the grinder impeller.
12. If impeller rubs or drags on shredding ring, loosen bolts in shredding ring plate and tap with plastic hammer to loosen, retighten screws. Be sure to pull screw down evenly, applying pressure on all three screws. **DO NOT TIGHTEN ONE SCREW CLEAR DOWN BEFORE ADJUSTING OTHER SCREWS.**

13. **ALWAYS** use a rag on the impeller when turning to prevent cutting hands on the sharp corners of shredding ring.



TO REPLACE CAPACITORS ONLY

CAUTION! DISCONNECT ALL POWER AND CONTROL WIRES TO MOTOR AT CONTROL PANEL BEFORE STARTING DISASSEMBLY OPERATIONS. DO NOT RELY ON OPENING CIRCUIT BREAKER ONLY.



1. Remove oil fill plug near the top of motor housing and pour oil out.
2. Loosen the cord nut on power cord until cord is loose enough to push cord down into motor housing.
3. Remove four bolts from motor housing and bump housing with a plastic hammer to loosen. Lay pump on its side.
4. Remove the housing carefully to be sure that enough cord is pushed into the housing to create no tension on cord.
5. Slide motor housing up far enough to expose the capacitors and to be able to lay the housing down.
6. Disconnect wiring from capacitor and loosen capacitor clamp and slide capacitor out. Replace with new capacitor, tighten clamp and reconnect per wiring diagram given in this manual.
7. Check all wiring connectors to be sure they are secure.
8. Be sure tetraseal gasket is in place.
9. Slide motor housing back onto pump while pulling the cord out slowly. Assemble motor housing with four bolts.
10. Re-assemble cord nut. Be sure washers are seated and cord is pulled up against the washers. Tighten nut securely.
11. Put pump upright and refill motor with Myers submersible pump oil. **DO NOT OVER FILL WITH OIL.** See figure 1 (page 3) for oil level. Reassemble washer, gasket, nut (item 20C) in motor housing. Retighten nut firmly, but do not over tighten.
12. Be sure pump turns freely before connecting power. Turn pump on side and turn impeller, using screwdriver in slotted shaft. Plug pump into receptacle to test operation. Pump must run quiet and free of vibration.

TO REPLACE MOTOR STATOR AND SHELL

CAUTION! DISCONNECT ALL POWER AND CONTROL WIRES TO MOTOR AT CONTROL PANEL BEFORE STARTING DISASSEMBLY OPERATIONS. NEVER RELY ON OPENING CIRCUIT BREAKER ONLY.



1. Remove motor housing as described above.
2. Disconnect all leads from power and ground wire and set pump upright.
3. Loosen four long screws holding motor and remove slowly.
4. Either remove previous capacitors and clamps from old motor and assemble onto new stator and shell or replace with new capacitors and assemble per wiring diagram.
5. Position bearing spring washer on top of upper ball bearing.
6. Position the "stator with shell" into place and line up screws with bosses and tighten the (4) long screws. Lay unit down in line with motor housing.
7. Be sure pump turns freely with screwdriver in impeller end of shaft.
8. Re-connect all terminals securely per wiring diagram.
9. Be sure tetraseal gasket is in place.
10. Reassemble motor housing and fill with oil as noted above in "Capacitor Replacement".

WIRING DIAGRAM

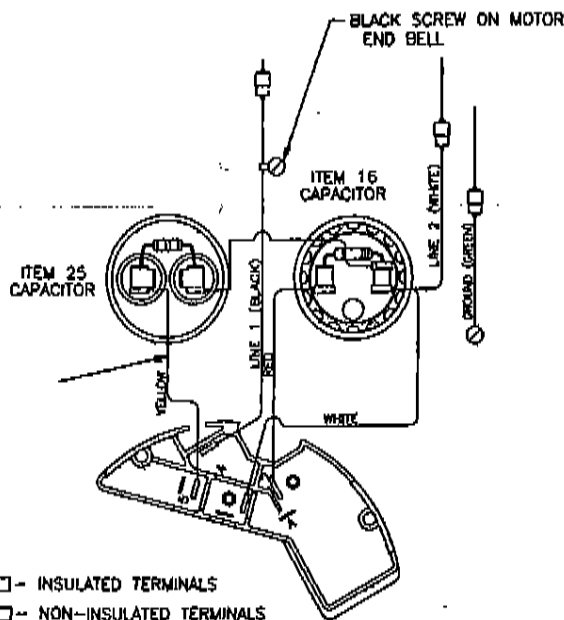

SYMPTOMS	SOLUTIONS
<p>Pump does not run or hum. See A, B, C, D, E or F.</p> <p>Pump runs but does not deliver water. See G, H, I, J, K or L.</p> <p>Pump runs and pumps out sump but does not stop. See M.</p> <p>Pump runs but delivers only small amount of water. See I, J, K, L or N.</p> <p>Fuse blows or circuit breaker trips when pump starts. See K, L, N, O or P.</p> <p>Motor runs for short time then stops. Then after short period starts again. Indicates tripping overload caused by symptom shown. See K, L, N or P.</p> <p>For any other symptoms call Myers Service Dealer.</p>	<p>A. Line circuit breaker may be off; or fuse if used, may be blown or loose.</p> <p>B. Water level in sump may be too low. Run in more water.</p> <p>C. Pump cord plug may not be making contact in receptacle..</p> <p>D. If pump is using the series cord plug, the two plugs may not be plugged tight together.</p> <p>E. Float may be stuck. Be sure float operates freely in basin. Check tether length of switch per instructions.</p> <p>F. If all symptoms check OK, motor winding may be open; take to service center for check.</p> <p>G. Check valve may be installed backwards. Arrow on valve points in direction of flow.</p> <p>H. Discharge shut-off valve, if used, may be closed.</p> <p>I. Pump may be air locked. Start and stop several times by plugging and unplugging cord. Check vent hole on pump case for plugging.</p> <p>J. Pump head may be too high. Pump cannot deliver water over 100 ft. vertical. Horizontal distance does not affect pumping, except loss due to friction.</p> <p>K. Inlet holes in pump base may be clogged. Remove pump and clean out openings.</p> <p>L. Impeller or volute openings may be plugged or partially plugged. Remove pump and clean per maintenance instructions. Check tether length of switch per instructions.</p> <p>M. Float is stuck in up position. Be sure float operates freely in basin.</p> <p>N. Pump impeller may be partially clogged causing motor to run slow, resulting in motor overload.</p> <p>O. Fuse size or circuit breaker is too small. Must be 20 amps.</p> <p>P. Defective motor stator. Return to Myers service center.</p>

23833A555

Myers

Pentair Pump Group

F. E. Myers, 1101 Myers Parkway, Ashland, Ohio 44805-1969
419/289-1144, FAX: 419/289-6658, www.femyers.com

Myers (Canada), 269 Trillium Drive, Kitchener, Ontario N2G 4W5
519/748-5470, FAX: 519/748-2553

MYERS LIMITED WARRANTY SUMP & RESIDENTIAL SEWAGE

During the time periods and subject to the conditions hereinafter set forth, F. E. Myers will repair or replace to the original user or consumer any portion of your new MYERS product which proves defective due to defective materials or workmanship of MYERS. Contact your nearest Authorized MYERS Dealer for warranty service. At all times MYERS shall have and possess the sole right and option to determine whether to repair or replace defective equipment, parts, or components. Damage due to lightning or conditions beyond the control of MYERS is NOT COVERED BY THIS WARRANTY.

WARRANTY PERIOD

Pumps: 12 months from date of purchase or 18 months from date of manufacture.

Labor, etc. Costs: MYERS shall IN NO EVENT be responsible or liable for the cost of field labor or other charges incurred by any customer in removing and/or reaffixing any MYERS product, part or component thereof.

THIS WARRANTY WILL NOT APPLY: (a) to defects or malfunctions resulting from failure to properly install, operate or maintain the unit in accordance with printed instructions provided; (b) to failures resulting from abuse, accident or negligence; (c) to normal maintenance services and the parts used in connection with such service; (d) to units which are not installed in accordance with applicable local codes, ordinances and good trade practices; or (e) unit is used for purposes other than for what it was designed and manufactured, and (f) if three phase submersible motors are installed on a single phase power supply using a phase converter or if three phase power is supplied by only two transformers, making an open Delta system.

RETURN OR REPLACED COMPONENTS: any item to be replaced under this Warranty must be returned to MYERS in Ashland, Ohio, or such other place as MYERS may designate, freight prepaid.

PRODUCT IMPROVEMENTS: MYERS reserves the right to change or improve its products or any portions thereof without being obligated to provide such a change or improvement for units sold and/or shipped prior to such a change or improvement.

WARRANTY EXCLUSIONS: MYERS SPECIFICALLY DISCLAIMS THE IMPLIED WARRANTIES OF MERCHANTABILITY AND FITNESS FOR A PARTICULAR PURPOSE AFTER THE TERMINATION OF THE WARRANTY PERIOD SET FORTH HEREIN.

Some states do not permit some or all of the above warranty limitations and, therefore, such limitations may not apply to you. No warranties or representations at any time made by any representatives of Myers shall vary or expand the provision hereof.

LIABILITY LIMITATION: IN NO EVENT SHALL MYERS BE LIABLE OR RESPONSIBLE FOR CONSEQUENTIAL, INCIDENTAL OR SPECIAL DAMAGES RESULTING FROM OR RELATED IN ANY MANNER TO ANY MYERS PRODUCT OR PARTS THEREOF. PERSONAL INJURY AND/OR PROPERTY DAMAGE MAY RESULT FROM IMPROPER INSTALLATION. MYERS DISCLAIMS ALL LIABILITY, INCLUDING LIABILITY UNDER THIS WARRANTY, FOR IMPROPER INSTALLATION -- MYERS RECOMMENDS FOLLOWING THE INSTRUCTIONS IN THE INSTALLATION MANUAL. WHEN IN DOUBT, CONSULT A PROFESSIONAL.

Some states do not allow the exclusion or limitation of incidental or consequential damages, so the above limitation or exclusion may not apply to you.

This Warranty gives you specific legal rights and you may also have other rights which vary from state to state.

In the absence of suitable proof of this purchase date, the effective date of this warranty will be based upon the date of manufacture.

DETERMINATION OF UNIT DATE OF MANUFACTURE: Submersible Sump pump (8-95) month and year stamped on pump nameplate; column sump pump month and year on red warranty tag.

Myers

Pental Pump Group

F. E. Myers, 1101 Myers Parkway, Ashland, Ohio 44805-1969
419/289-1144, FAX: 419/289-6658, www.femyers.com