

**INSTALLATION AND SERVICING  
INSTRUCTIONS FOR MYERS  
115 VOLT ALARM AND  
CONNECTION BOX**

# CA-SS4 Connection and Alarm Box

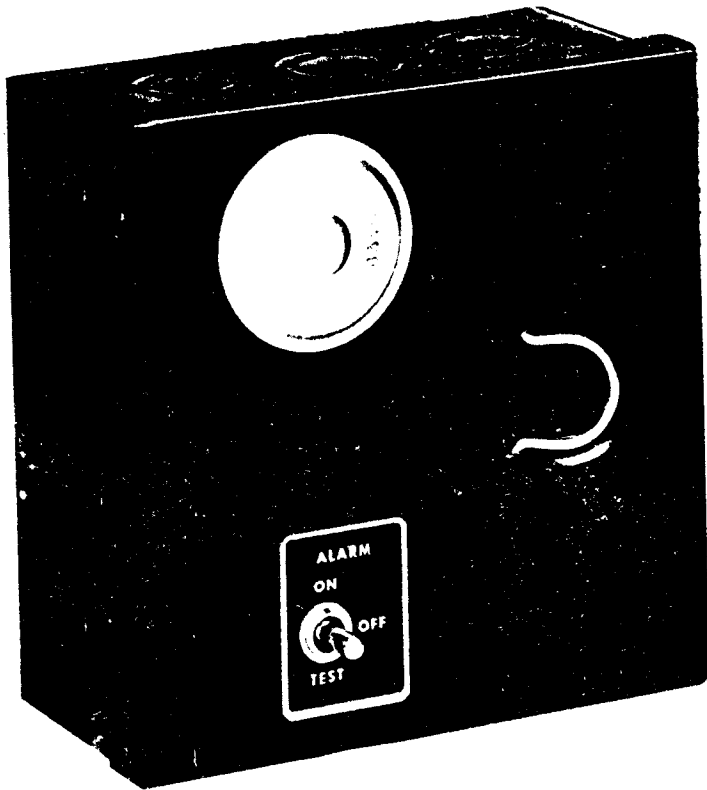



# TYPICAL INSTALLATION DRAWING OF PUMP, TANKS AND CONTROLS

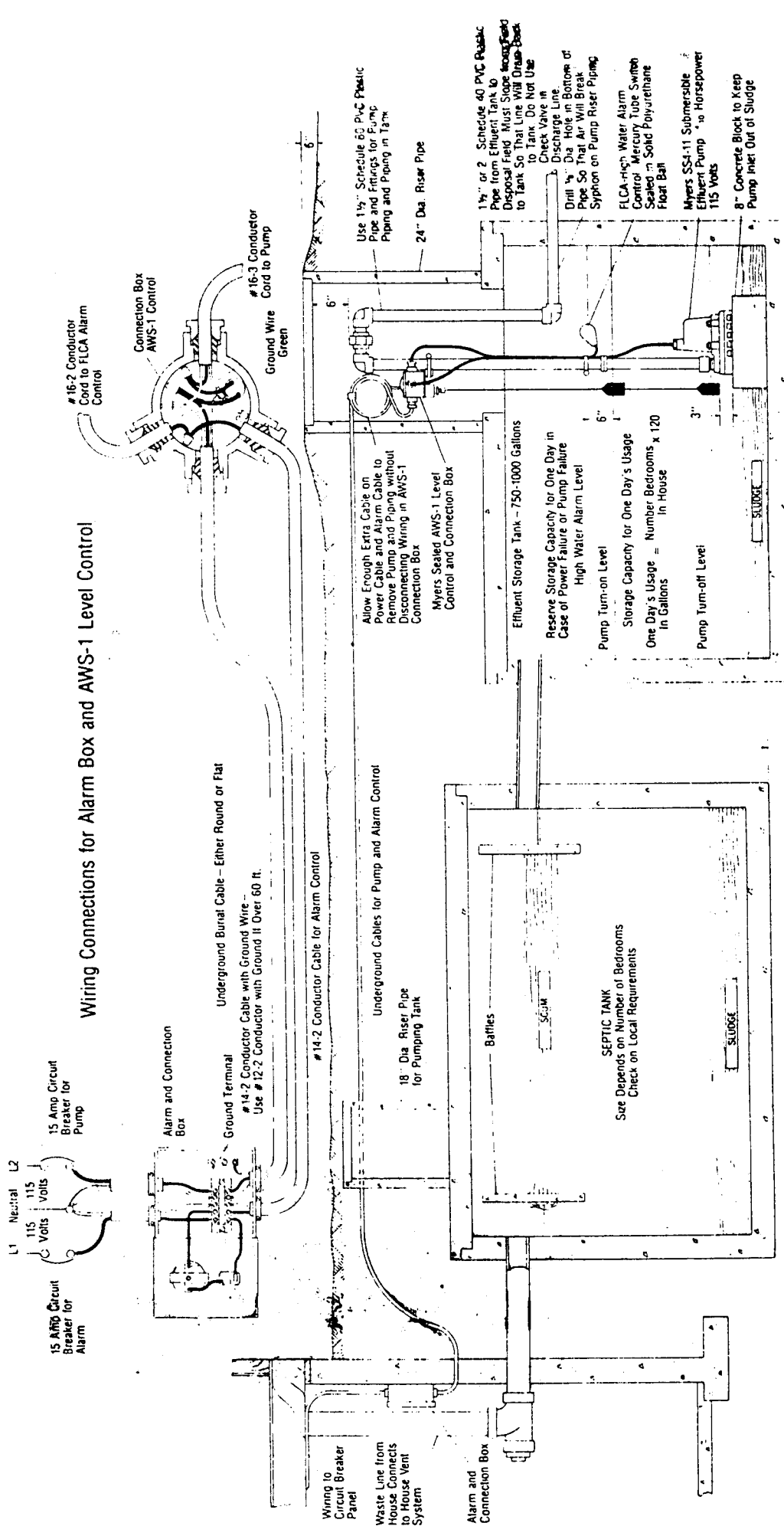

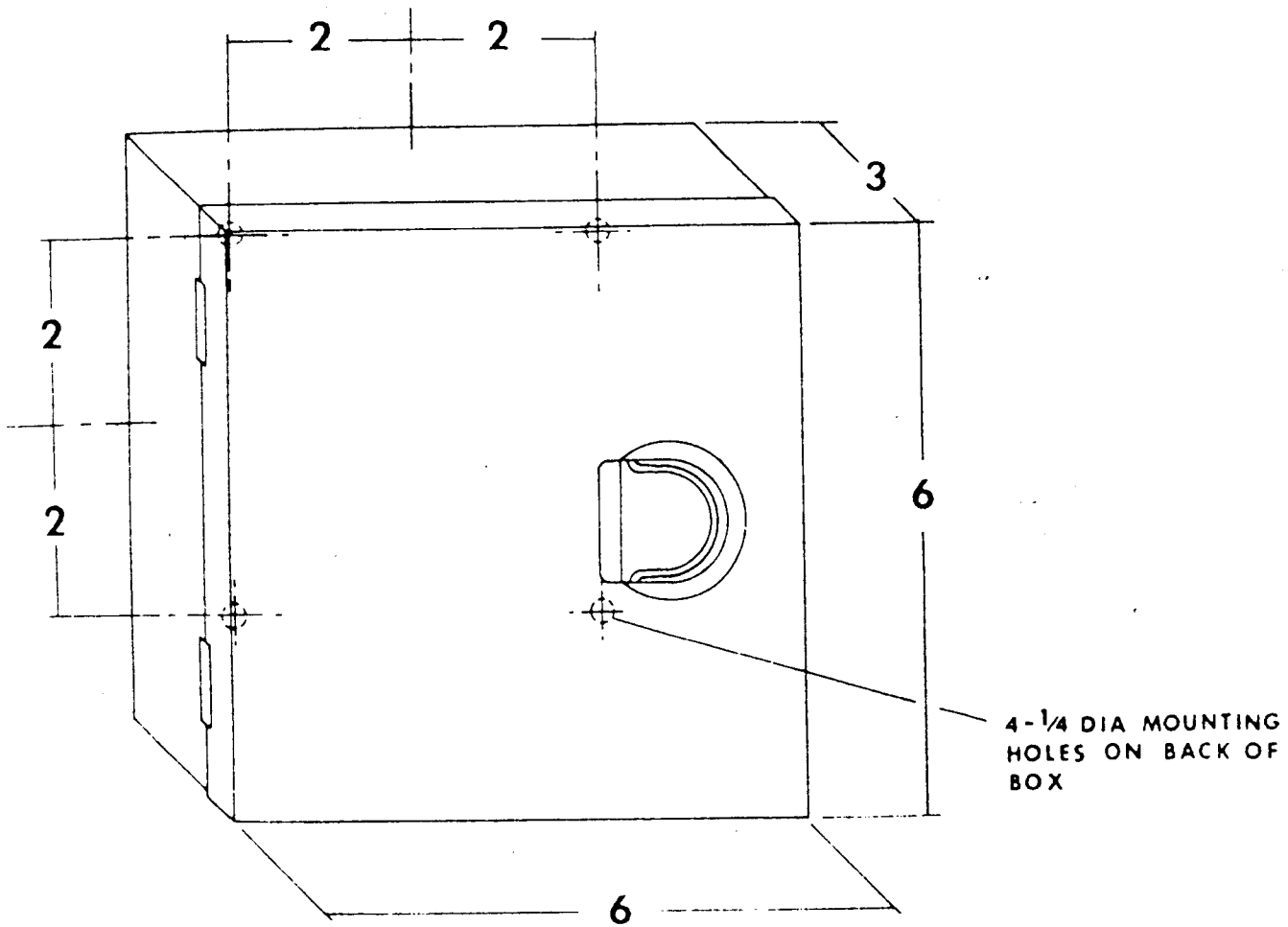

# Myers ESD

1977, F. E. Myers Co.  
Printed in U.S.A. 777

F. E. MYERS CO. DIVISION OF  
400 ORANGE STREET, ASHLAND, OH 44805 **McNEIL**  
CORPORATION

